

MAGNICOOL LINE

MAGNICOOL 10 FIRM



- Plates in Eliosoft and Elioform, for optimal back support
- The surface on the Eliosoft plate gently massages the body during sleep, creating a regenerating effect
- Supports the body weight in 5 different zones: head, shoulders, hips, legs and feet
- Padding in Hypoallergenic fiber Memoform and Super Soft fiber confer extra comfort
- Removable Magnicool fabric, cool and thermoregulating, dissipate moisture which keeps your body fresh and cool



MEMOFORM



MAGNICOOL



ELIOSOFT
ELIOFORM

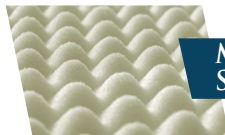

MASSAGING
SYSTEM

- A** COVER
Magnicool
- B** PADDING
Hypoallergenic fiber, Memoform and Super Soft fiber
- C** COMFORT LEVEL
Eliosoft (5 cm)
- D** BASE LAYER
Elioform (16 cm)

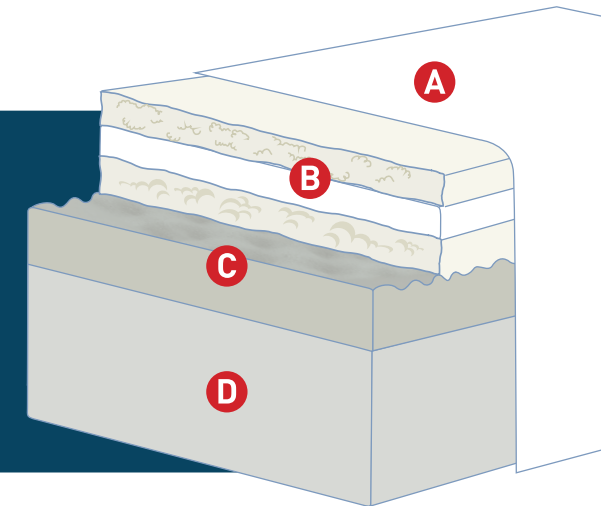

- FIRM
- MEDIUM FIRM
- MEDIUM SOFT
- SOFT
- SUPER SOFT



BENEFITS
Cool - Breathable
Cozy - Massaging
Multi-zone
Dissipate moisture



WARRANTY
10 years



Thermoregulating



Removable cover



HEIGHT
25 cm

CERTIFICATIONS



100%
Made in Italy



OEKO-TEX® Class I



Studies have been carried out on ergonomics in conjunction with the UNIVERSITY OF FLORENCE.



EC Declaration of conformity,
MEDICAL DEVICE



SLEEP IS LIFE'S GREATEST PLEASURE.